

Fanps

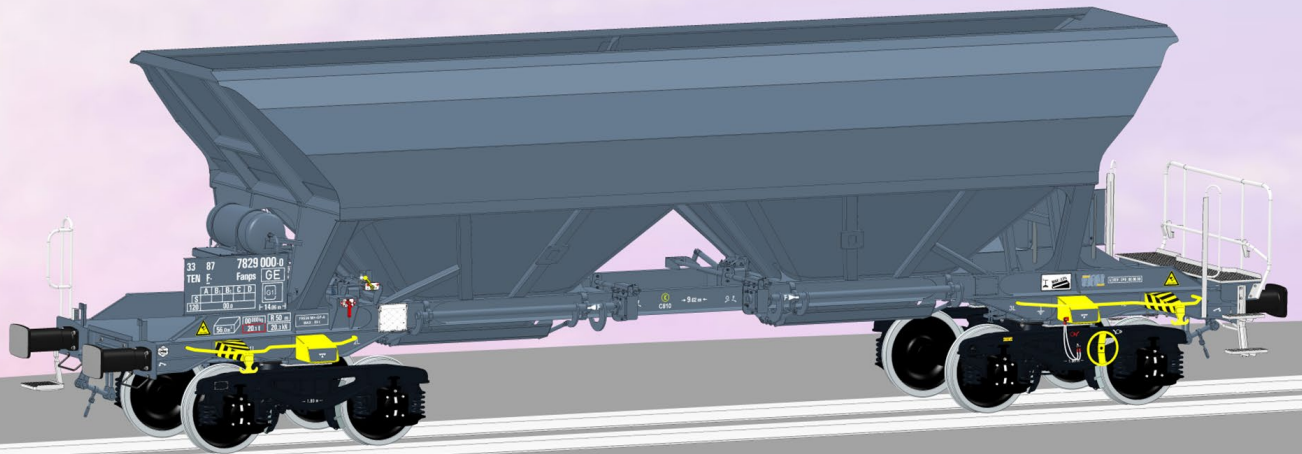

53 m³

**HOPPER WAGON (EX)
FOR AGGREGATE TRANSPORT
Aggregatetransport hopper-wagen (EX)
Wagon trémies transport d'agrégats (EX)**

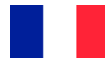
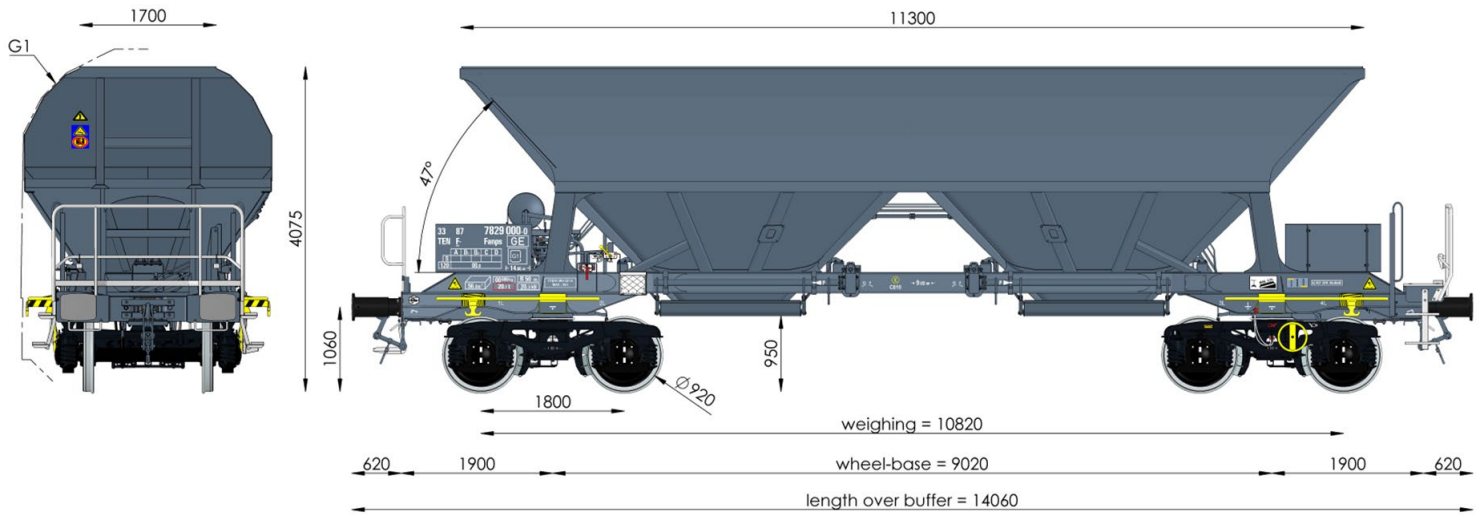

Technical data

Technische Daten

Données techniques

Wagon type	Wagentyp	Type de wagon	Fanps
Tare	Eigengewicht	Tare	19.5 T
Carrying capacity	Nutzlast	Charge utile	70.5 T
Gross weight	Gesamtgewicht	Charge brute	90 T
Bogie / Max. axle load	Drehgestell / Radsatzlast max.	Bogie / Charge max. par essieu	Y25 Lsi-C / 22.5 T
Wheelsets	Radsatz	Essieux	25T (BA303)
Brake regime	Bremssystem	Régime frein	S
Loaded speed	Geschwindigkeit beladen	V max. en charge	100 Km/h
Empty speed	Geschwindigkeit leer	V max. à vide	120 km/h
Brake configuration	Bremsen-Konfiguration	Configuration freinage	1 Bgu / MH-GP-A / (K) C810
R. min (single wagon)	R. min (als Einzelwagen)	R. min (wagon seul)	50 m
Vehicle Gauge	Wagenbegrenzungslinie	Gabarit	G1 - TSI
Marking	Markierung	Marquage	TEN - GE
Temperature class	Temperaturklasse	Classe de température	T1
Capacity	Ladevolumen	Capacité	56 m ³



Route de l'Ombrée
18 200 ORVAL - FRANCE
+33 2 48 96 07 39
www.inveho.eu